

MA202 (cn_en) 安装说明

DuraDock multi – E..., ME... [尺寸 1-4]
圆形多极电气组件

目录

安全须知	2-3
工具准备	4
电缆准备	5
压接	7
触子安装	8
正确装配	9

MA202 (cn_en) Assembly instructions

DuraDock multi – E..., ME... [sizes 1-4]
Circular, multipole electrical inserts

Content

Safety Instructions	2-3
Tools required.....	4
Cable preparation	5
Crimping.....	7
Installation of the contact.....	8
Control of correct assembly	9

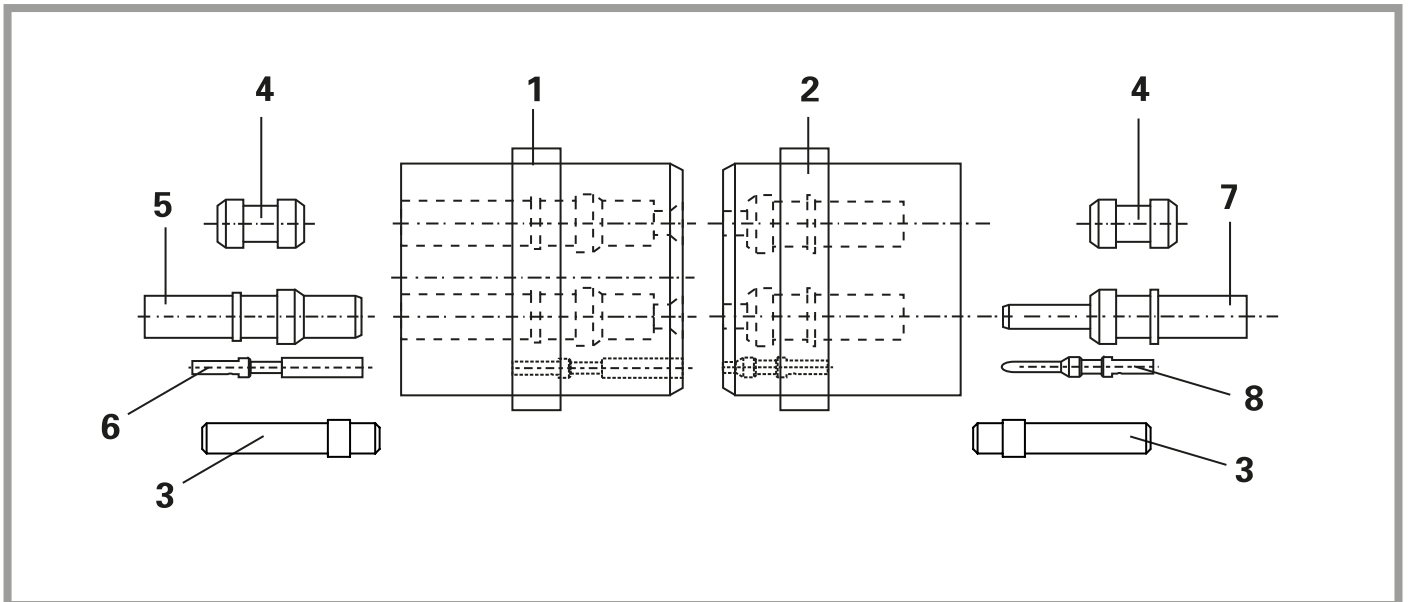

1. 插座支撑块
2. 插头支撑块
3. 盲塞 MVS1/1 ¹⁾
4. 盲塞²⁾
5. 插座 Ø 5-11 mm
6. 插座 Ø 1-3 mm
7. 插头 Ø 5-11 mm
8. 插头 Ø 1-3 mm

¹⁾盲塞 MVS1/1, 适用于Ø 1 mm金属针, 须将盲塞较长的一侧从入线孔方向插入绝缘座。盲塞仅适用于 E1-18+PE (插针 + 插座侧)。对于 E01-18PE, 不可使用盲塞。如要更换, 允许完全用所有触子填充这部分。

²⁾适用Ø1.5-8mm金属针的盲塞颜色: Ø 1/白色; Ø 1,2-2/蓝色; Ø 2,36 和 Ø 3/黄色; Ø 5/白色; Ø 6/黑色; Ø 8/黑色

1. Socket carrier
2. Pin carrier
3. Blind plugs MVS1/1 ¹⁾
4. Blind plugs ²⁾
5. Socket Ø 5-11 mm
6. Socket Ø 1-3 mm
7. Plug Ø 5-11 mm
8. Plug Ø 1-3 mm

¹⁾ The blind plug MVS1/1, suitable for nominal Ø 1 mm, must be assembled with the long side facing the direction of the cable entry. The blind plug is only suitable for the E1-18+PE (Pin + socket side). For the E01-18PE a blind plug may not be used. In place of this it is permitted to completely fill the part with all contacts.

²⁾ Suitable for nominal-Ø 1,5 - 8 mm Colours: Ø 1/white; Ø 1,2-2/blue; Ø 2,36 and Ø 3/yellow; Ø 5/white; Ø 6/black; Ø 8/black

安全须知

仅可使用 Stäubli 指定的组件和工具。自行装配时，切勿背离本手册所述的制备及装配说明，否则 Stäubli 无法保证产品安全性或性能达到官方技术参数。请勿以任何方式修改产品。

可与 Stäubli 元件插合的非 Stäubli 原厂制造的连接器的，在某些情况下，某些制造商甚至将其描述为“与 Stäubli 兼容”，但该连接器并不符合长期稳定安全的电连接要求，而且出于安全考虑，不得与 Stäubli 元件插合在一起。因此，Stäubli 对因此类连接器（即未经 Stäubli 批准）与 Stäubli 元件插合而造成的任何损失不承担任何责任。

如您未遵守上述警告，则 Stäubli Electrical Connectors (Stäubli) 不承担任何责任。

Safety instructions

Use only the components and tools specified by Stäubli. In case of self-assembly, do not deviate from the preparation and assembly instructions as stated herein, otherwise Stäubli cannot give any guarantee as to safety or conformity with the technical data. Do not modify the product in any way.

Connectors not originally manufactured by Stäubli which can be mated with Stäubli elements and in some cases are even described as "Stäubli-compatible" by certain manufacturers do not conform to the requirements for safe electrical connection with long-term stability, and for safety reasons must not be plugged together with Stäubli elements. Stäubli therefore does not accept any liability for any damages resulting from mating such connectors (i.e. lacking Stäubli approval) with Stäubli elements.

Stäubli Electrical Connectors (Stäubli) does not accept any liability in the event of failure to observe these warnings.

应用范围

连接器只可用于机械向导安装板的应用。安装板的设计决定连接系统的锁紧、导向以及浮动程度。

Intended use

Connectors can only be used for applications in mechanically guided mounting plates. The locking, guiding and floating of the connection must be ensured by the design of those mounting plates.



IEC 60417-6182 安装需电气专业知识

产品可由具备电气技能或受过此方面指导的人员依照适用的安全法规进行装配或安装。

Installation, electrotechnical expertise

The products may be assembled and installed by electrically skilled or instructed persons duly observing all applicable safety regulations.



IEC 60417-6042 注意电击风险

请在断电状态下工作
操作电气装置时，请遵守五项安全规定。
各电气装置确定后，应按照规定顺序执行以下五项基本要求（除非另有必要理由）：

- 完全分离；
- 确保不会重新连接；
- 确认无工作电压；
- 进行接地和短路；
- 针对临近带电部件提供防护。

任何从事此工作活动的人员均应具备电气技能或受过此方面指导，或者由同等能力的人员监督。

来源：EN 50110-1:2013

最终应用时，还应检查电击防护。

Caution, risk of electric shock

Work in a de-energized state
Follow the five safety rules, when working on electrical installations.
After the respective electrical installations have been identified, the following five essential requirements shall be undertaken in the specified order unless there are essential reasons for doing otherwise:

- disconnect completely;
- secure against re-connection;
- verify absence of operating voltage;
- carry out grounding and short-circuiting;
- provide protection against adjacent live parts.

Any person engaged in this work activity shall be electrically skilled or instructed, or shall be supervised by such a person.

Source: EN 50110-1:2013

Protection against electric shock shall be checked in the end-use applications too.



IEC 60417-6070 在负载下请勿断开连接

仅带电压时插拔是允许的。

Do not disconnect under load

Plugging and unplugging when live is permitted.

安全指令

Safety instructions



ISO 7000-0434B
注意

每次使用连接器前,需提前检查外部是否有缺陷(尤其是绝缘层)如有安全疑虑,必须咨询专业人员或更换连接器。

连接器的防水功能可参考相关产品的IP保护等级。

未插合的连接器必须防潮防尘。被污染的公母连接器不应插合使用。

插针和插座外壳屏蔽

对于电压 > 60 V DC 或 > 30 V AC, 外壳必须连接地线(地线/PE)。如果使用 EMC 电缆格兰头, 外壳也可以用于屏蔽。可能需要将其与安装面板绝缘。



产品使用说明或技巧

更多技术参数请见产品目录。

Caution

Each time the connector is used, it should previously be inspected for external defects (particularly the insulation). If there are any safety concerns, an electrically skilled person must be consulted or the connector must be replaced.

The plug connectors are watertight in accordance with the product specific IP protection class.

Unmated plug connectors must be protected from moisture and dirt. The male and female parts must not be plugged together when soiled.

Pin and socket housing shielded

For voltages > 60 V DC or > 30 V AC, the housing must be connected to earth (ground/PE). If EMC cable glands are used, the housing can also be used for shielding purposes. It may be necessary to insulate it from the mounting panel/plate.

Useful hint or tip

For further technical data please see the product catalog.

工作准备

Tools required



表1/Tab. 1

图 ill.	位置 Pos.	型号 Type	订货号 Order No.	导体横截面 Conductor cross-section		L± 0,5	描述 Description	MA
				mm ²	AWG			
1	a	M-PZ13 ¹⁾	18.3700	-	-	-	压接钳 / Crimping pliers	MA224
	b	MES-PZ-TB5/6	18.3701	6	10	11	压接模具 / Crimping die	
	c	MES-PZ-TB8/10	18.3702	10	-	13		
	d	MES-PZ-TB9/16	18.3703	16	-	13		
	e	MES-PZ-TB11/25	18.3704	25	-	16		
	f	MES-PZ-TB13/35	18.3705	35	2	16		
2	g	M-PZ-T2600	18.3710	-	-	-	压接钳 / Crimping pliers	MA226
	h	TB8-17 ²⁾	18.3711	10 + 70 ²⁾	8 + 2/0	13/26	压接模具 / Crimping die	
	i	TB9-13 ²⁾	18.3712	16 + 35 ²⁾	6 + 2	13/16		
	j	TB11-14,5 ²⁾	18.3713	25 + 50 ²⁾	4 + 1/0	16/23		
	k	TB20	18.3714	95	3/0	28		
3	l	M-CZ ³⁾	18.3800	-	-	-	压接钳 / Crimping pliers	MA085
	m	MES-CZ	18.3801	-	-	-	压接钳 / Locator	
	n	MES-CZ1,5/2	18.3802	0,5 – 1,5	-	7	压接模具 / Crimping die	
	o	MES-CZ1/1,57	18.3803	0,25 – 1,5	-	57		
4		CZK2-230 CZK2-110	18.3111 18.3112	-	-	-	压接钳箱 / Crimping pliers case	MA306
		MTB11-25-50	18.3023	25	4	16	压接模具 / Crimping die	
		MTB13-35-50	18.3024	35	2	16		
		MTB14,5-50-50	18.3025	50	1/0	23		

¹⁾ 适用最大压接线缆截面积35mm²。

²⁾ 压模两侧都可用于压接, 数字8+17, 9+13, 11+14,5 代表压接套的外径尺寸,

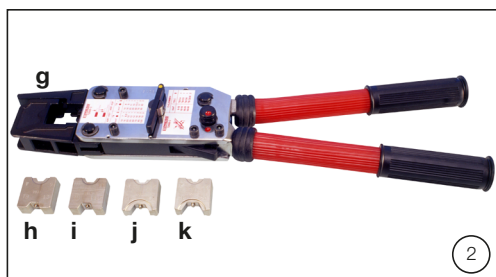
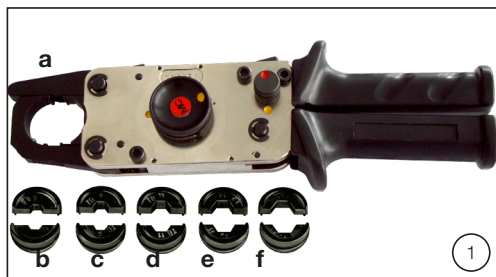
³⁾ 适用于信号触子。

¹⁾ Crimping pliers up to 35 mm² max.

²⁾ Each crimping die can be used on 2 sides.
Numerals 8 + 17, 9 + 13, 11 + 14,5 = outer-Ø of crimping sleeves.

³⁾ For pilot contacts.



图 ill.	压入工具(插针/插座) Insertion tool pin/socket	订货号 Order no.	触子直径 For nom.-Ø pin/socket
5	ME-WZ1/1,2	18.3000	1 / 1,2
	ME-WZ1,5/2	18.3003	1,5 / 1,57 / 2 / 2,36
	ME-WZ3	18.3010	3
	ME-WZ5	18.3013	5
	ME-WZ6	18.3016	6
	ME-WZ11/38	18.3021	8 / 11



图 ill.	拔出工具(插针) Extraction tool pin	订货号 Order no.	触子直径 For nom.-Ø contact
6	MSA-WZ1/1,2	18.3002	1 / 1,2
	MSA-WZ1,5	18.3005	1,5 / 1,57
	MSA-WZ1,5/109	18.3020	1,5 ¹⁾
	MSA-WZ2	18.3009	2
	MSA-WZ3	18.3012	2,36 / 3
	MSA-WZ5	18.3015	5
	MSA-WZ6	18.3018	6
	MSA-WZ8	18.3022	8
	MBA-WZ5	18.3014	11

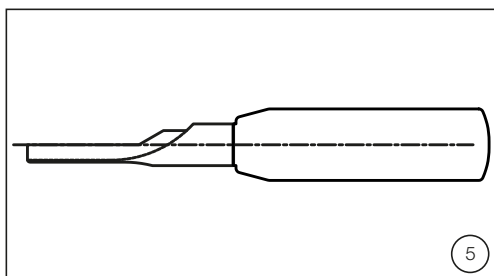

图 ill.	拔出工具(插座) Extraction tool socket	订货号 Order no.	触子直径 For nom.-Ø contact
7	MBA-WZ1/1,2	18.3001	1 / 1,2
	MBA-WZ1,5	18.3004	1,5 / 1,57
	MBA-WZ1,5/109	18.3019	1,5
	MBA-WZ2	18.3008	2 / 2,36
	MBA-WZ3	18.3011	3
	MBA-WZ5	18.3014	5
	MBA-WZ6	18.3017	6 / 8
	MSA-WZ8	18.3022	11

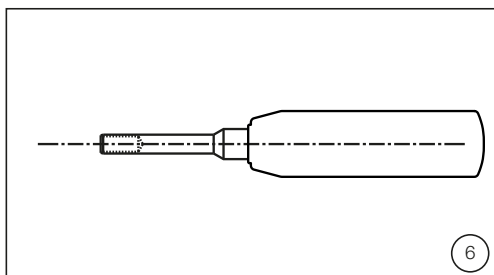

注意:
PEEK 支撑块和触子的安装工具: 参见 MA303, www.staubli.com/electrical

Note:
Assembly tools for PEEK carriers and contacts: see MA303, www.staubli.com/electrical

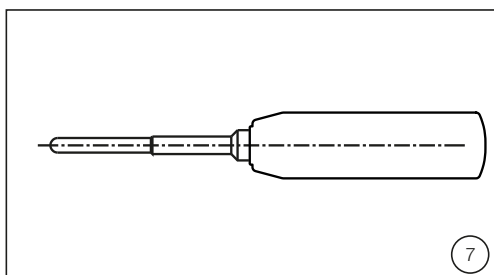
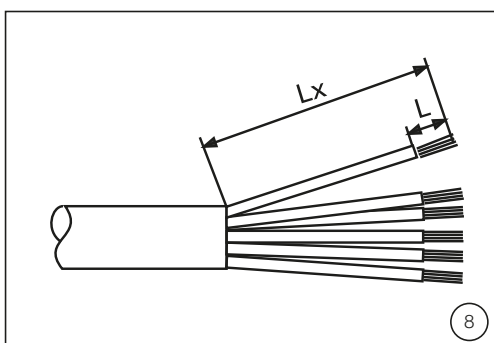
电缆准备

(图8)
剥除电缆绝缘层到尺寸 Lx。Lx 取决于外壳尺寸和电缆的类型。标准 Stäubli 外壳对应 Lx 尺寸约为:

Cable preparation

(ill. 8)
Strip cable insulation to dimension Lx. Lx depends on housing size and type of cable. Approximate figures for standard Stäubli housings:

外壳尺寸 Housing size	Lx (mm)
1	40
2	40
3	55
4	70

表2/Tab. 2

(表2)
剥除电缆绝缘层到尺寸 L

(Tab. 2)
Strip wire insulation to dimension L

插头/插座的公称直径 Nom-Ø pin/socket	导体横截面 Conductor cross-section		L ± 0,5	压接钳 M-CZ 编号 Crimping pliers M-CZ 定位器-编号 Selector no.	M-PZ13 用的压接模具 crimping die for M-PZ13	M-PZ-T2600 用的压接模具 crimping die for M-PZ-T2600	CZK 用的压接模具 crimping die for CZK...
mm	mm ²	AWG	mm				
1 / 1,5	0,14 / 0,2 / 0,34 / 0,5	26 / 24 / 22 / 20	5	1 / 2 / 3 / 4			
1,2	0,5 – 0,75	22 / 20	5	3 / 4			
1,57	0,5 – 1,5	20 / 18 / 16	5	4 / 5 / 6			
1 / 1,5 / 2	0,75	18	7	5			
	1	18	7	5			
1,5 / 2	1,5	16	7	6			
2	1,5 / 2,5	16 / 14	7	7 / 8			
2,36	0,5 – 1,5	20 / 18 / 16	7	4 / 5 / 6			
3	2,5	14	7	7			
	4	12	7	8			
5 / 6	6	10	11		MES-PZ-TB5/6		
	10		13		MES-PZ-TB8/10		
6	16		13		MES-PZ-TB9/16	TB9-13	
6 / 8	25		16		MES-PZ-TB11/25	TB11-14,5	MTB11-25-50
8 / 11	35	2	16		MES-PZ-TB13/35	TB9-13	MTB13-35-50
11	38	-	18			TB12-14	MTB13-35-50
11	50	1/0	23			TB11-14,5	MTB14,5-50-50

导体横截面 Conductor cross-section	定位器位置 Selector position
mm ²	
0,14	18/5
0,25	18/5
0,5	16/6
0,75	16/6
1,0	14/7
1,5	14/7
2,5	12/8

⚠ 注意
对于插头和插座组件 ME3-36+PE...2/25的连接, 尺寸 L 为 7±0,5。对于压接工具 (MEZ-CZ) 的定位器位置, 必须使用下面的设置, 在与 0,14 mm² 至 1 mm² 的横截面配合时, 必须在压接套筒内使用转接套。线端套圈符合 DIN 46228 标准。横截面 1,0/6 长且镀银的适合此用途。(例如 Klauke 72S/6)

⚠ Attention
For the connections of pin and socket inserts ME3-36+PE...2/25 the size L is 7±0,5. For the selector position of the crimping tool (MES-CZ) the following settings have to be used and when working with cross-sections of 0,14 mm² to 1 mm² it is necessary to use a reducing sleeve in the crimp barrel. Wire end ferrules accord. to DIN 46228 nom. cross-section 1,0/6 long and silver plated are suitable for this purpose. (e.g. Klauke type 72S/6).

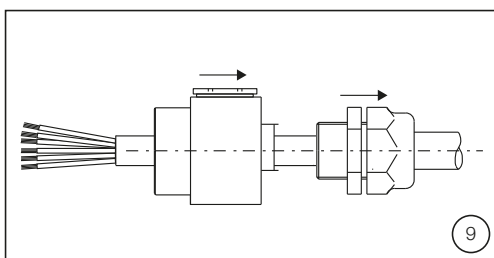

压接触子

⚠ 注意 (图9)
在压接之前, 将电缆格兰头和外壳后端滑到电缆上。

Crimping the contacts

⚠ Attention (ill. 9)
Slip the cable gland and back section of housing on the cable before crimping.

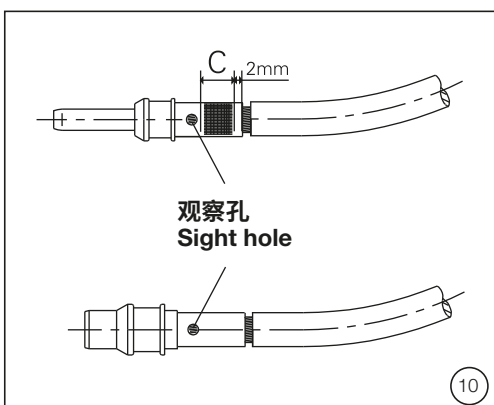

(图10)
在压接套筒的压接区域C插入工具。将导线完全插入压接套筒中。观察孔中必须能看到导线。

(ill. 10)
When inserting the crimping sleeve in the tool, use crimp zone (C). Fully insert lead into the crimping sleeve. Leads must be visible in the sight hole.

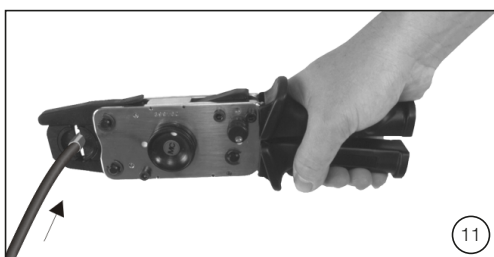

(图11)
压接线缆, 同时将其轻轻推入套筒。

(ill. 11)
Crimp the wire, pushing it gently into the sleeve while doing so.

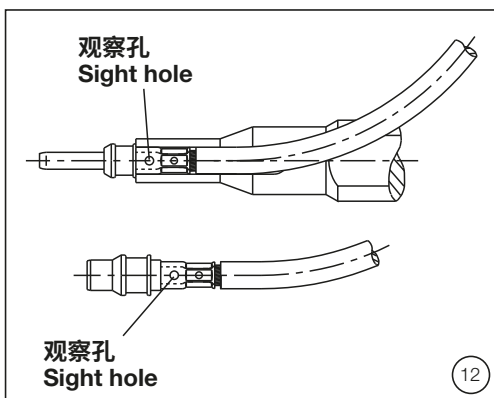

(图12)
压接前后, 必须能在观察孔中看到导线。检查线缆是否可以从压接套管中拉出或转出。

(ill. 12)
Wire must be visible in the sight hole before and after crimping. Check that the wire can not be pulled or turned out of the crimping sleeve (Control !)

● 注意:
i 在压接热电偶压力触子时, 请遵守以下规定:
1 - 将触子安装在适合的电缆上:
- 将NiCr触子安装在NiCr导体上
- 将NiAl触子安装在NiAl导体上
2 - 连接插座触子时, 留出一小圈电缆。

● Note:
i When crimping on thermocouple pressure contacts, please observe the following:
1- Fit contacts on the appropriate cables:
- NiCr contacts on NiCr conductors
- NiAl contacts on NiAl conductors
2- When attaching the socket contact, leave a small loop of cable.

安装触子

注意:

为便于安装, 插入触子前, 请将插针或插座支撑块浸入酒精或工业酒精内。不要使用任何油腻介质(无滑石粉)。用盲塞堵住任何空置触子插孔。

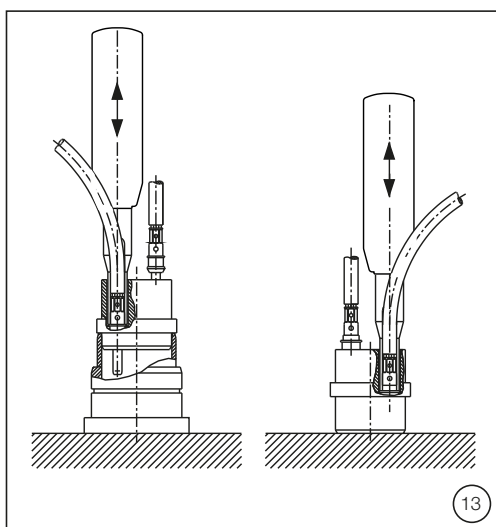

(图13)

用手将触子从连接侧(较大孔径)插入插头或插座支撑块的插孔内。用压入工具(参见第4页)压入触子。对于插针安装, 建议使用正确尺寸外壳的前部分作为装配夹具。对于插座安装, 直接将插座支撑块放在一个平台上。

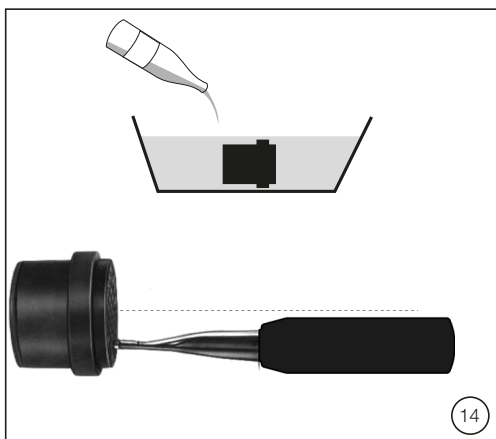

(图14)

安装或移除触子时, 请务必保持工具平直。

Installation of the contacts

Note:

To facilitate installation, immerse the pin or socket carrier in spirits or industrial alcohol before inserting the contacts. Do not use any greasy media (no talc). Plug any unoccupied contact holes with blind plugs.

(ill. 13)

Insert contacts by hand into the contact holes of the pin or socket carrier from the connection side (larger hole diameter).

Press in the contacts with the insertion tool (see page 4).

For pin installation, it is advisable to use a front section of the right size housing as assembly jig. For socket installation, simply place socket carrier directly onto a flat bench.

(ill. 14)

Be sure to keep tool straight when installing or removing contacts.

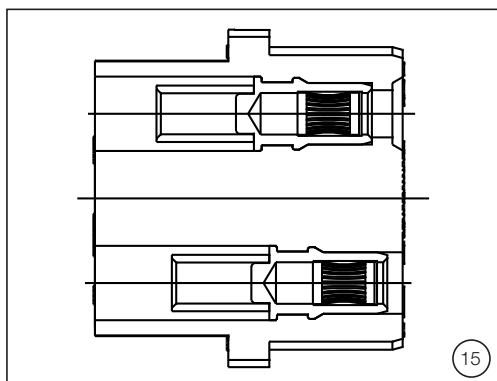

15

正确装配

(图15 + 16)

ME1.../ME2...

所有PE类型触子的位置都比其他触子位置更靠前(先断后通)。

ME3.../ME4...

公头组件 ME3.../ME4...中, 尺寸 $\leq \varnothing 2$ mm的PE触子位置靠前。尺寸 $\geq \varnothing 3$ mm的PE触子与其他触子处于同一水平位置(不存在位置较高的触子)。对于母头组件, 尺寸 $\geq \varnothing 3$ mm的插座, PE触子的位置均靠前。

在带有屏蔽触子的支撑块(例如, 混合支撑块)中, 与控制触子相比屏蔽触子处于前端位置, 但在PE触子之后。您可以在产品图纸上找到相关细节。

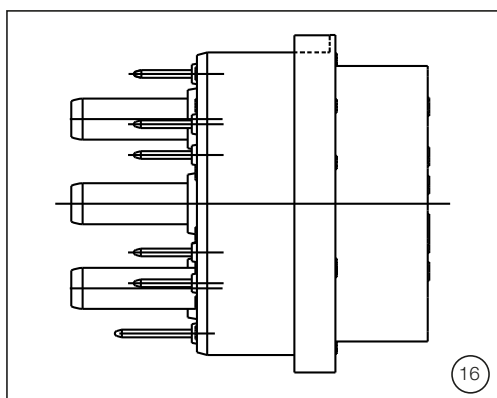

16

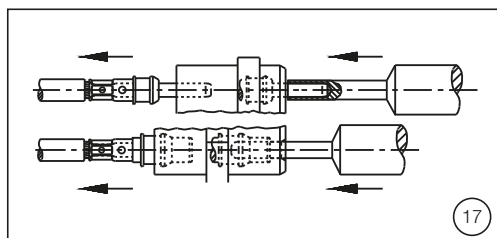

17

(图17)

可以用插座拔出工具(第4页)将压入过头的插座调整到合适的安装位置。

如果出于维修或因为安装错误, 用对应的拔出工具将触子从触子支撑块拆除(第4页), 然后再正确重新安装。

Control of correct assembly

(ill. 15 + 16)

ME1.../ME2...

all types of PE pins are in advanced position (mating first, braking last) compared to the other contacts.

ME3.../ME4...

In male inserts ME3... and ME4... only PE pin contacts up to $\varnothing 2$ mm are in advanced position. PE contacts of $\varnothing 3$ mm and above are on the same level as the other pins (no leading contact). Regarding female inserts, for sockets of $\varnothing 3$ mm or larger, the PE socket is in advanced position.

In contact carriers (e.g. hybrid carriers) with a shield contact (S) the shield contact is in advanced position compared to the control contacts, but lagging behind the PE contact.

You will find the relevant details on the product drawings.

(ill. 17)

Sockets pressed in too far can be turned back to their proper seating position with the socket extraction tool (page 4).

By repairs or installation errors, re-move the contacts from the contact carrier with the respective extraction tool (see page 4) and then reinstall them correctly.

注意 / Notes:

注意 / Notes:

注意 / Notes:

生产商/Manufacturer:
Stäubli Electrical Connectors AG
Stockbrunnenrain 8
4123 Allschwil/Switzerland
Tel. +41 61 306 55 55
Fax +41 61 306 55 56
mail ec.ch@staubli.com
www.staubli.com/electrical